



HDTV Switch

Model AVS 4.1

Instruction Manual

www.avlinx.com

Introduction

Thank you for your purchase of the AVLinX AVS4.1 HDTV Switch. At AVLinX, we are motivated by a passion for quality audio/video equipment that fulfills the technological needs of our customers. Every item we sell is designed to provide the ultimate in signal integrity, system integration, and user control.

This product has been designed and manufactured to accommodate up to four HDTV audio and video signal inputs to a single output. For the best results when using this product, we recommend that you take the time to read through this manual before you attempt to connect it to any other equipment. This manual will accustom you to the various system connections and operating features associated with this product. Keep this manual in a safe place for any future reference.

In the spaces provided below, record your model and serial number. Refer to these numbers when trying to acquire information or servicing requirements for this product.

Model: AVS4.1 Serial Number: _____

Safety Precautions



WARNING

RISK OF ELECTRIC SHOCK
DO NOT OPEN



CAUTION: TO REDUCE THE RISK OF FIRE OR ELECTRIC SHOCK, DO NOT DISASSEMBLE. DANGEROUSLY HIGH VOLTAGES ARE PRESENT INSIDE THE UNIT. REFER SERVICING TO QUALIFIED PERSONNEL ONLY.

Safety Instructions

CAUTION: PLEASE READ AND OBSERVE ALL WARNINGS AND INSTRUCTIONS GIVEN IN THIS MANUAL.

1. Do not expose this unit to rain or moisture.
2. Do not expose this unit to high heat.
3. Do not install this unit near any heat sources.
4. Do not remove the cover at any time. Refer all servicing to qualified personnel only.

Table of Contents

Introduction	2
Safety Precautions	2
Safety Instructions	2
Table of Contents	3
Identification	4
Accessories	4
Front Panel	4
Back Panel	4
Remote Control	5
-Operating Range	5
-Inserting Batteries	5
The AVS4.1	6
Controls	6
The RS-S232 Communication Port	6
Connections	6-7
Component Video Connections	6
Analog / Digital Audio Connections	6
Operations	8-9
Changing the Unit's Power State	8
-Using the Input Selector Button	8
-Using the Remote Control	8
-Using the RS-232 Communication Port	8
Switching inputs	9
-Using the Input Selector Button	9
-Using the Remote Control	9
-Using the RS-232 Communication Port	9
Using an Alternate Remote Control	10-12
Programming an Input Selector Key	10
Programming a Power Button	11-12
-Power On/Off	11
-Power On Only	11
-Power Off Only	12
Restoring Default Remote Control Codes to the Unit	12
Troubleshooting	13-14
Warranty	15
Limited Warranty	15
Limitation of Liability	15
Servicing	16
Specifications	16
Appendices	17-18

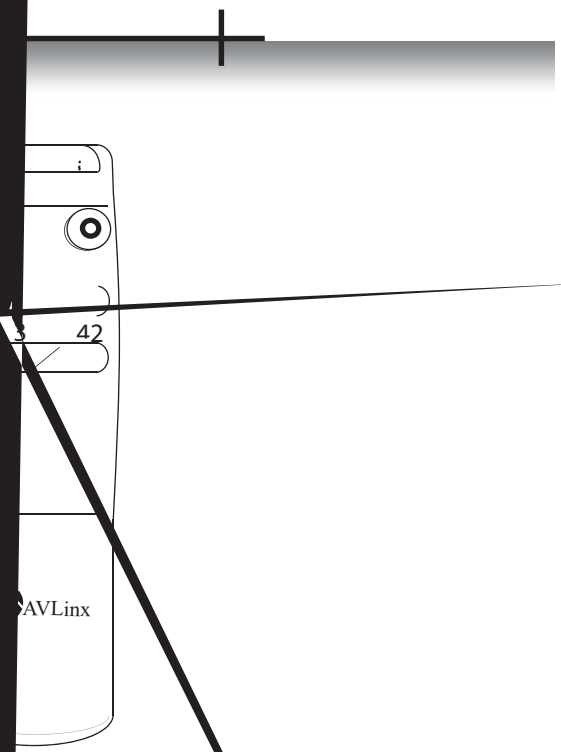

e

For best results when using this remote, point the signal transmitter on the remote control at the IR sensor window from no more than 30 feet away and at an angle of no more than 45 degrees.

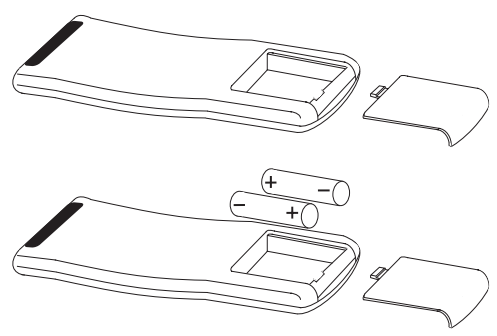

Optical D

The AVS4.1

The AVS4.1 comes standard with four component video inputs, each paired with digital and analog audio connections that pass the full HDTV bandwidth through the signal paths. The passive switch design for all analog signals minimizes distortion from active components. The AVS4.1 is also compatible with other high-end video formats like RGBHV and S-Video with proper cabling.

Controls

The unit includes a seven-button custom remote control, as well as controls on the unit itself, that allow the user to switch easily between up to four high-bandwidth sources. The AVS4.1 is also programmed with the ability to learn new codes from other remote controls for executing all of its functions.

RS-232 Communication Port

Aside from standard audio/video inputs on the rear of the unit, the AVS4.1 includes a RS-232 communication port as an optional way of controlling the unit. It interfaces well with system controllers, such as those made by Crestron[®] and AMX[®], or it can simply be connected to a home PC and issued commands via a terminal program, such as Microsoft[®] HyperTerminal. All the features accessible through the remote control are also accessible via the RS-232 communication port. For detailed technical information, please see Appendix B on pages 17-18.

Connections

Component Video Connections

The AVS4.1 is designed to switch a variety of audio and video signals, but most users will choose to use it in a component video application as shown on page 7.

- For this usage, connect the corresponding red (Pr or Cr), green (Y), and blue (Pb or Cb) outputs of a component video source to the same connectors on the chosen AVS4.1 input.
- To connect the output of this unit, connect the three component outputs on the AVS4.1 to the corresponding red (Pr or Cr), green (Y), and blue (Pb or Cb) inputs of a component receiver (TV, projector, A/V receiver, etc.).
- (NOTE: For component video connections, 75-ohm component video cable with red, green, and blue labeled connectors must be used. Other types of cable cannot be used without sacrificing signal quality.)

Analog / Digital Audio Connections

In addition to video signals, the AVS4.1 can be used to simultaneously switch analog audio or digital audio signals

- Standard analog audio may be connected by matching the red and white analog audio outputs on the source to the red (R/V) and white (L/H) RCA connectors on the chosen AVS4.1 input.
- Digital audio may be connected using either digital coax (SPDIF) or optical (Fiber) formats. The chosen output from the digital audio source is simply connected to the chosen AVS4.1 digital audio input through the proper cable type.

Connections

Typical Component Video Connections

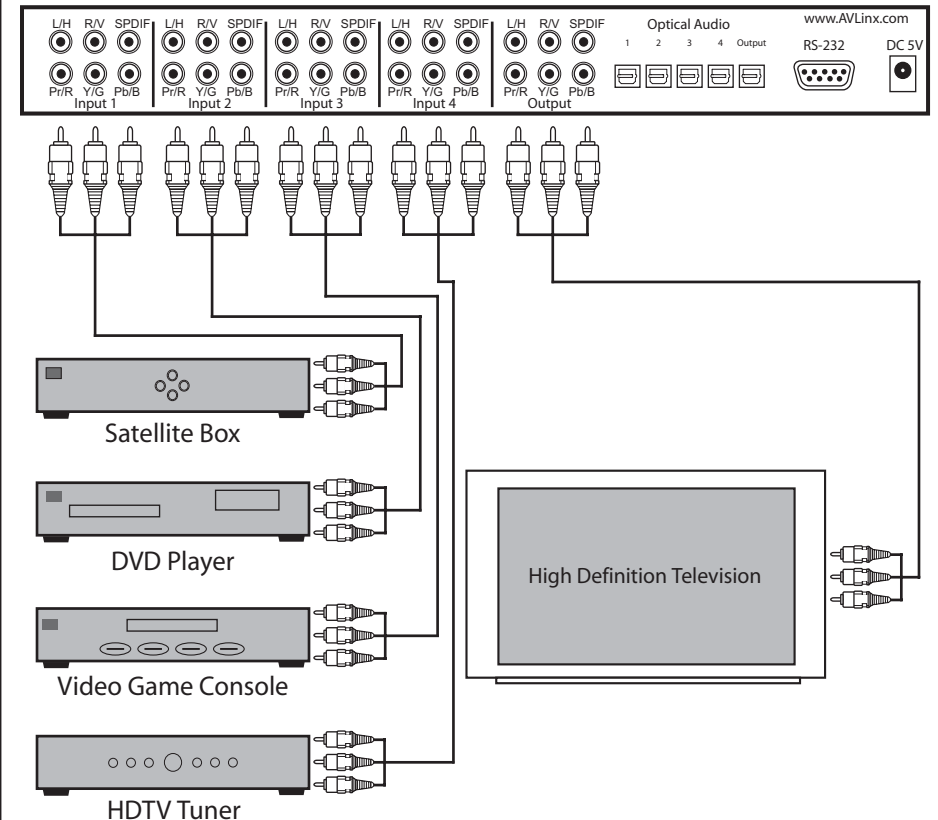

- Coax and optical formats transmit the same data over different mediums, so if a source has both types of outputs the user may choose to use whichever is more convenient.
- Never connect both a digital coax cable and an optical cable to the same input number at the same time. Data errors will result. Both types, though, may have their outputs connected simultaneously if desired.
- (NOTE: For the coaxial digital audio connections, 75-ohm digital audio cable should always be used. Other types of cable cannot be used reliably in all situations.)

Other Connections

The AVS4.1 is capable of switching signals for other types of video formats such as composite, S-Video, and RGBHV. Each of the individual signals in these formats can be switched through the AVS4.1 using a proper converter to interface with the RCA jacks at the input and output. Please note that the AVS4.1 does not convert signal formats from one type to another, so each signal path from all inputs to the corresponding output should use the same signal format.

Operations

Changing the Unit's Power State

Once the unit is plugged in, the power state can be changed in one of the following three ways. An audible click will be heard whenever there is a change in the power state of the unit.

Using the Input Selector Button

- Pressing the input selector button on the front panel once while the unit is turned off will power the unit on. The last known active input will be selected and will be indicated by the green LED on the front panel.
- (NOTE: Do not hold the input selector button down for a period longer than two seconds. See pages 10-12 for details.)

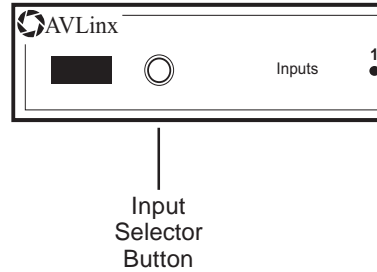

Using the Remote Control

- Pressing the power key on the remote control will cause the unit to turn on or off depending on its current power state.
- When turning the unit on, the last known active input will be selected and will be indicated by the green LED on the front panel.
- Pressing any of the direct input keys on the remote while the unit is off will cause the unit to power on with that selected key's input becoming active immediately.
- Pressing either the + or – key on the remote while the unit is off will cause the unit to turn on with the last known active input selected.

Using the RS-232 Communication Port

- Through the RS-232 communication port, the user can change the power state by entering one of the following codes to coordinate with the desired task.

RS-232 Power State Commands

Command	Function	Response Verbose On	Response Verbose Off
PT<cr>	Toggle On/Off	Py<cr><lf> where y is the new power state	AP<cr><lf>
P1<cr>	Turn power on	P1<cr><lf>	AP<cr><lf>
P0<cr>	Turn power off	P0<cr><lf>	AP<cr><lf>

(See Appendix B on page 17-18 for more details on the RS-232 operations.)

Operations

Switching Inputs

There are three ways to switch inputs on the unit: using the input selector button on the front panel, using the remote control, and using the RS-232 communication port. An audible click will be heard whenever there is a change in the power state of the unit.

Using the Input Selector Button

- Pressing the input selector button on the front panel will select the next input following the active input. The green LED on the front panel will designate the input that is presently selected.
- (NOTE: Refrain from holding the input selector button down for a period longer than two seconds. See pages 10-12 for details.)

Using the Remote Control

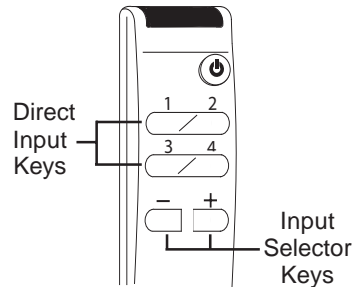

- The direct input keys can be used to select the corresponding input on the unit. The green LED on the front panel will designate the input that is actively selected.
- The + and – keys can also be used to select inputs. By pressing the + key, the unit will switch to the next input following the one actively selected. By pressing the – key, the unit will move to the input preceding the one actively selected.

Using the RS-232 Communication Port

- Through the RS-232 communication port, the user can select a respective input by entering one of the following codes to coordinate with the desired task.

RS-232 Input Selection Commands

Command	Function	Response Verbose On	Response Verbose Off
I1<cr>	Switch active input to 1	I1<cr><lf>	A1<cr><lf>
I2<cr>	Switch active input to 2	I2<cr><lf>	A1<cr><lf>
I3<cr>	Switch active input to 3	I3<cr><lf>	A1<cr><lf>
I4<cr>	Switch active input to 4	I4<cr><lf>	A1<cr><lf>
I+<cr>	Increment active input by 1	Ix<cr><lf>, where x is the new input	A1<cr><lf>
I-<cr>	Decrement active input by 1	Ix<cr><lf>, where x is the new input	A1<cr><lf>

(See Appendix B on page 17-18 for more details on the RS-232 operations.)

Using an Alternate Remote

The AVS4.1 comes preprogrammed to recognize command codes from the supplied AVLinX remote control. An alternate remote can be used in place of the supplied remote. The original AVLinX remote control can be used to program most universal remote controls by following the instructions for that product. Universal and pre-programmed remote users may also choose to teach the AVS4.1 a new set of pre-programmed codes. A small sample list of compatible manufacturers' codes is listed in Appendix A on page 17. Please consult your universal remote documentation on how to set pre-programmed codes. When an alternate remote is configured with a suitable pre-programmed code set, the AVLinX remote functions can be assigned to the alternate remote by performing the following steps:

Programming Input Selector Keys

1. Turn the unit on.
2. Make sure there are no other infrared remote control signals interfering with the unit during the programming process.
3. Press and hold the input selector button on the front panel for 5-10 seconds. Continue holding the button until all steps are completed.
4. Aim the supplied AVLinX remote directly at the IR sensor window and press the key you are reassigning.
5. If the unit recognizes that command, the active input's green LED will turn off briefly then come back on.
6. Aim the new remote that is to be used for programming directly at the IR sensor window and press the key that will be performing the desired function.
7. If the unit recognizes the command on the new remote, the active input's green LED will blink twice to confirm that the unit has set the new key code.
8. Repeat Steps 1-7 for the remaining direct input selector keys.

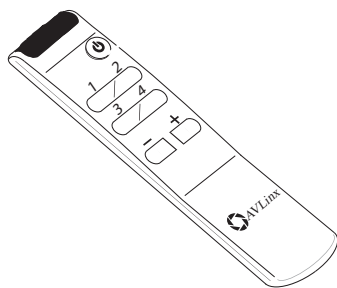
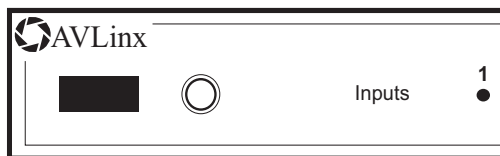

Using an Alternate Remote

Programming a Power Key

A power key can be programmed to perform one of three different tasks: turn the unit on or off in a toggle progression, only turn the unit on, or only turn the unit off.

Power On / Off

1. Turn on the unit.
2. Make sure there are no other infrared remote control signals interfering with the unit during the programming process.
3. Press and hold the input selector button on the front panel for 5-10 seconds. Continue holding the button until all the steps are completed.
4. Aim the supplied AVLinX remote directly at the IR sensor window and press the power key. The active input's green LED will turn off briefly then come back on to recognize that the unit has begun the sequence to reassign a power key.
5. After the LED comes back on, press the power key on the AVLinX remote again. This tells the unit that the user is reassigning the power toggle feature.
6. Aim the new remote at the IR sensor window and press the key that will now be controlling the power toggle feature of the unit.
7. If the unit recognizes the new command on the new remote, the active input's green LED will blink twice to confirm that the unit has set the new key code.

Power On Only

1. Turn on the unit.
2. Make sure there are no other infrared remote control signals interfering with the unit during the programming process.
3. Press and hold the input selector button on the front panel for 5-10 seconds. Continue holding the button until all the steps are completed.
4. Aim the supplied AVLinX remote directly at the IR sensor window and press the power key. The active input's green LED will turn off briefly then come back on to recognize that the unit has begun the sequence to reassign a power key.
5. After the LED comes back on, press the + key on the AVLinX remote. This tells the unit that the user is reassigning the power on feature.
6. Aim the new remote at the IR sensor window and press the key that will now be controlling the power on feature of the unit.
7. If the unit recognizes the new command on the new remote, the active input's green LED will turn off for a second and then blink twice to confirm that the unit has set the new key code.

Using an Alternate Remote

⦿ Power Off Only

1. Turn on the unit.
2. Make sure there are no other infrared remote control signals interfering with the unit during the programming process.
3. Press and hold the input selector button on the front panel for 5-10 seconds. Continue holding the button until all the steps are completed.
4. Aim the supplied AVLinX remote directly at the IR sensor window and press the power key. The active input's green LED will turn off briefly then come back on to recognize that the unit has begun the sequence to reassign a power key.
5. After the LED comes back on, press the – key on the AVLinX remote. This tells the unit that the user is reassigning the power off feature.
6. Aim the new remote at the IR sensor window and press the key that will now be controlling the power off feature of the unit.
7. If the unit recognizes the new command on the new remote, the active input's green LED will turn off for a second and then blink twice to confirm that the unit has set the new key code.

Restoring Default Remote Control Codes to the Unit

In the event that the default remote control codes need to be restored, the following procedure should be followed.

1. Turn on the unit.
2. Making sure not to press any keys on the remote, press and hold the input selector button on the front panel for 30 seconds until the active input's green LED turns off. This indicates that 30 seconds has elapsed and the button can be released.
3. Release the input selector button. After the button is released, the green LED will turn back on. This signifies that the codes have been reset to their default settings.



Troubleshooting

Before calling AVLinX for servicing assistance, review the following guide for a possible solution to the problem.

Problem	Cause	Solution
The unit will not turn on.	-Power cord is not connected. -The outlet in the wall connected to the unit is turned off. -Incorrect power pack is being used.	-Plug the cord securely into the back of the unit as well as the wall. -Plug the unit into a non-switched outlet or turn the outlet switch on. -Make sure to use the power pack that was supplied with the unit or a suitable equivalent.
RS-232 port is not working	-Cable not connected. -Improper cable being used. -Commands not formatted properly. -Communication port parameters incorrect.	-Make sure the cable is plugged in properly. -Connect the proper RS-232 cable. If connecting to a control system, make sure to use the proper cable. A non-standard cable is sometimes specified. -Be sure to use capital letters and follow all commands with a carriage return. -Set the communication port to the settings specified in this manual.
Poor component video picture.	-Cable too long. -Cable not securely fastened. -Poor quality cable.	-Cables over 5m may not work at highest resolutions. -Use thumbscrews to securely fasten the cable to the connector. -Use high quality cable especially at longest distances.



Troubleshooting

Problem	Cause	Solution
Digital audio does not work	-Both optical and coax cables are plugged into a single input at the same time. -Improper cable is being used with SPDIF connection.	-Be sure to only use one type of connection at the input. -Be sure to use 75-ohm digital coax cables, especially for long distances.
Alternate remote does not work	-Remote's data format is not compatible with the AVS4.1.	-Set the remote to one of the recommended compatible codesets.
Alternate remote has a limited range.	-Alternate remotes that use a different frequency than the AVLinx remote may have reduced range.	-Try using a recommended codeset that uses 38khz carrier frequency.
The AVLinx remote is not working.	-Batteries are low. -The IR Sensor window is blocked. -Input selector button was held for more than 45 seconds.	-Replace batteries. -Provide a clear line of sight between the remote and the IR sensor window. -Follow procedures on page 12 for "Restoring Default Remote Control Codes."
Resetting default remote control codes did not work	-Input selector button was held for more than 45 seconds. -Input selector button was held for less than 30 seconds.	-Perform steps again and release the input selector button after the green LED goes off when 30 seconds have elapsed. -Perform steps again and release the input selector button after the green LED goes off when 30 seconds have elapsed.

(For any problems not addressed in this section, please refer to the Servicing information on page 16 of this manual.)

Warranty

Limited Warranty

AVLinx Systems LLC warrants this product to be free from defects in materials and workmanship that adversely affect the operation described in this manual for a period of one (1) year from the date of sale. This warranty applies to the original owner of the product purchased directly through AVLinx Systems LLC or an authorized reseller. AVLinx Systems LLC will have the option to repair or replace defective equipment covered by this warranty at its sole discretion. Products that have not been operated in accordance with the instructions contained in this document, or have been subjected to abnormal conditions including, but not limited to, physical abuse, electrical surges, excessive moisture, temperature extremes or tampering will not be eligible for service under terms of the warranty agreement. Products purchased from an authorized reseller needing eligible warranty service should be returned to the point of sale. Warranty service for products purchased directly from AVLinx Systems LLC as well as service for all products not covered under the terms of the warranty, may be arranged by contacting AVLinx Systems LLC. Products should not be returned to the factory for any reason without first contacting AVLinx Systems LLC for instructions. The safe and undamaged shipment of items to AVLinx Systems LLC is the responsibility of the customer.

Limitation of Liability

All implied warranties regarding merchantability and fitness for a particular use are limited to the valid warranty period. All other implied warranties are disclaimed. AVLinx Systems LLC is not responsible for consequential, indirect, special, incidental or other damages resulting from the use or attempted use of this product, no matter how those damages may have occurred. These limitations shall be in effect where permitted by law.

All of the information contained in this manual is believed to be accurate. AVLinx Systems LLC will not be responsible for damages resulting from inadvertent omissions or errors in the manual. The information contained in this manual and the technical specifications of the ADV2.1 are subject to change without notice.

Servicing

If you have any questions concerning the servicing of this or any of our other products, please contact us through one of the following:

Mailing Address: AVLinX Systems LLC Phone: (214)-764-4095
4760 Preston Rd Ste. 244-196 Fax: (214)-764-3978
Frisco, TX 75034

Email: support@avlinx.com
Website: http://www.avlinx.com

If you have any comments or suggestions on how we can add more value to your purchase or better serve your needs with future products or technical support, please contact us through the following:

Email: feedback@avlinx.com

Specifications

HDTV AVS4.1

Power Supply	DC 7.5-9 @200mA
Power Consumption (standard operation)	2.0W Max.
Weight	4.5 lbs. (2.05 kg)
Dimensions	17"W x 6"D x 1.72"H (19"W with Rack Mount brackets)
Bandwidth (-.1dB)	41Mhz
Bandwidth (-3dB)	160Mhz

Appendices

Appendix A: Compatible Remote Control Format

The following are products whose remote control data format is compatible with the AVS4.1. The format used by the AVS4.1 is the NEC type with a 38khz carrier frequency. Many universal or multi-function remote controls are able to be programmed to emulate the remote control codes from these products. By configuring your system remote to transmit codes from these products, and following the steps in the section "Using an Alternate Remote Control" on pages 10-12 to teach your AVS4.1 the new codes, the AVS4.1 will work with many of the remote controls you already have. This is very advantageous to those with a master system remote control or those wanting to reduce remote control by consolidating functions onto fewer remotes. These products are a very small sample of those whose data format can be recognized by the AVS4.1. Other settings may be tried, and the default AVS4.1 codes may always be restored by following the instructions in "Restoring Default Remote Control Codes to the Unit" on page 12.

Phillips[®]DVD
Emerson[®]CD
Videosonic[®]VCR
Abex[®]TV
Minutz[®]TV
Asha[®]VCR

Appendix B: R-S232 Communication Port

The R-S232 port on the AVS4.1 can be used to control all aspects of the unit including changing inputs, changing the power state, querying the input and power states, and reading its firmware revision information. The RS232 USART* on the AVS4.1 operates at 9600 baud, 8 data bits, 1 stop bit, and no parity bits, which means that the unit issuing commands must be configured with those settings as well. All commands issued to the unit should be terminated with a carriage return. All responses from the unit are terminated with a carriage return followed by a line feed.

When the power cord is connected to the AVS4.1 (regardless of the power on or off state), the RS-232 communication port will send the code "AS<cr><lf>" to acknowledge that the unit's startup sequence has completed. Once this response has been received from the AVS4.1, the unit is then ready to perform all functions. See the following table for a listing of available commands and their arguments.

All commands that do not have some form of default response are acknowledged with an 'A' followed by the associated command character from the table below. The AVS4.1 has a verbose mode, which is disabled by default, that provides the status of the input and power state every time the state changes. It is equivalent to issuing a Get command to return status information. All R-S232 commands are inhibited while the front input selector button is pressed, such as the case during IR code programming and reset functions. If commands are sent wholly during these events, they will be ignored.

ADV2.1 Recognized RS-232 Commands

Command	Function	Response Verbose On	Response Verbose Off
I1<cr>	Switch active input to 1	I1<cr><lf>	A1<cr><lf>
I2<cr>	Switch active input to 2	I2<cr><lf>	A1<cr><lf>
I3<cr>	Switch active input to 3	I3<cr><lf>	A1<cr><lf>
I4<cr>	Switch active input to 4	I4<cr><lf>	A1<cr><lf>
I+<cr>	Increment active input by 1	Ix<cr><lf>, where x is the new input	A1<cr><lf>
I-<cr>	Decrement active input by 1	Ix<cr><lf>, where x is the new input	A1<cr><lf>
PT<cr>	Toggle the power state	Py<cr><lf>, where y is the new power state	AP<cr><lf>
P1<cr>	Turn power on	P1<cr><lf>	AP<cr><lf>
P0<cr>	Turn power off	P0<cr><lf>	AP<cr><lf>
V1<cr>	Enable Verbose mode	V1<cr><lf>	Not Applicable
V0<cr>	Disable Verbose mode	Not Applicable	AV<cr><lf>
G1<cr>	Get the active input	Ix<cr><lf>, where x is the active input	Ix<cr><lf>, where x is the active input
GP<cr>	Get the power state	Py<cr><lf>, where y is the power state	Py<cr><lf>, where y is the power state
GV<cr>	Get the verbose mode state	Vz<cr><lf>, where z is the verbose mode state	Vz<cr><lf>, where z is the verbose mode state
GF<cr>	Get the firmware name and revision	AVS4.1 Rev. X.X, where X.X is the revision number	AVS4.1 Rev. X.X, where X.X is the revision number

The RS-232 communications port will issue an error for the following situations. The error will consist of 'E' followed by a decimal number and a carriage return and line feed.

- E2 – Command not valid
- E3 – Argument (second character) for received command not valid
- E6 – RX buffer overflowed